

Max screw torque 130 mNm  
Max traction 300N

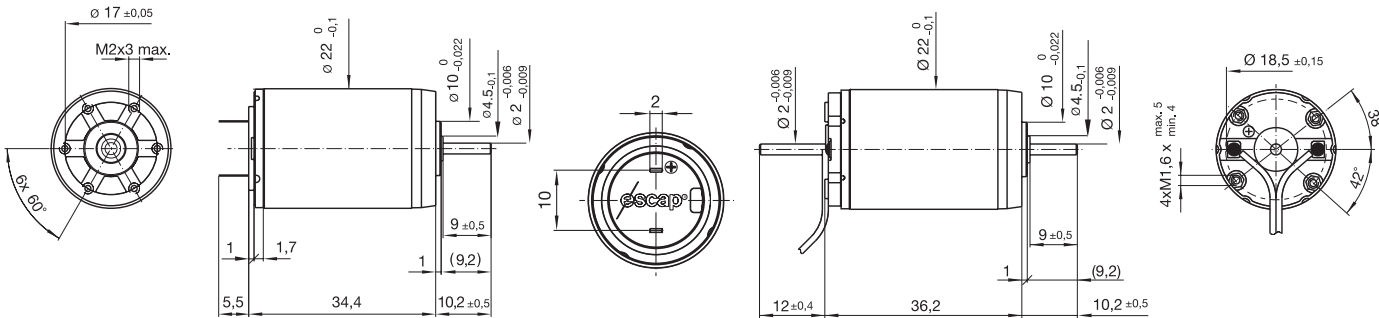

dimensions in mm  
mass: 68 g

22V28 ☉☉ • 201

22V48 ☉☉ • 204

**Winding Type**

☉☉

-216P

-213P

-216E

-213E

-210E

-208E

**Measured Values**

Measuring voltage	V	4.5	6.0	9.0	12.0	15.0	24.0
No-load speed	rpm	6400	7100	6700	7600	7500	6300
Stall torque	mNm (oz-in)	18.2 (2.59)	16.0 (2.27)	17.1 (2.42)	15.0 (2.13)	11.5 (1.63)	11.5 (1.62)
Average No-load current 1)	mA	18/27	15/22	9/13.5	7.6/11	6.0/9	3.2/4.8
Typical starting voltage 1)	V	0.06/0.2	0.08/0.3	0.10/0.4	0.15/0.6	0.24/1.0	0.4/1.6

**Max. Recommended Values**

Max. continuous current	A	1.55	1.15	0.77	0.58	0.40	0.23
Max. continuous torque	mNm (oz-in)	10.27 (1.45)	9.09 (1.29)	9.66 (1.37)	8.48 (1.20)	7.4 (1.05)	8.13 (1.15)
Max. angular acceleration	10 <sup>3</sup> rad/s <sup>2</sup>	105	113	98	105	102	134

**Intrinsic Parameters**

Back-EMF constant	V/1000 rpm	0.70	0.84	1.33	1.56	1.97	3.75
Torque constant	mNm/A (oz-in/A)	6.7 (0.95)	8.0 (1.13)	12.7 (1.80)	14.9 (2.11)	18.8 (2.66)	35.8 (5.07)
Terminal resistance	ohm	1.65	3.00	6.70	11.9	24.5	75.0
Motor regulation R/k <sup>2</sup>	10 <sup>3</sup> /Nms	37	47	42	54	69	58
Rotor inductance	mH	0.10	0.15	0.50	0.55	0.80	3.30
Rotor inertia	kgm <sup>2</sup> 10 <sup>-7</sup>	3.90	3.20	3.90	3.20	2.90	2.40
Mechanical time constant	ms	14	15	16	17	20	14

1) Single Shaft/double shaft

**Executions**

		Single Shaft	For F16	For E9
<b>Gearbox</b>	<b>Page</b>	<b>22V28</b>	<b>22V28</b>	<b>22V48</b>
R22	105	202	202	225
M22	106	201	201	204
K24	107	202	202	225
K27	108	202	202	225
RG1/8	111	201	201	204
RG1/9	112	201	201	204
K38	110	201	201	204
L10	115	201	201	204

- Thermal resistance: rotor-body 6°C/W  
body-ambient 22°C/W
- Thermal time constant - rotor / stator: 10 s / 460 s
- Max. rated coil temperature: 100°C (210°F)
- Recom. ambient temperature range: -30°C to +85°C (-22°F to +185°F)
- Viscous damping constant: 0.1 x 10<sup>-6</sup> Nms
- Max. axial static force for press-fit: 150 N
- End play: ≤150 µm  
Radial play: ≤30 µm  
Shaft runout: ≤10 µm
- Max. side load at 5 mm from mounting face:  
- sleeve bearings 3 N  
- ball bearings 6 N
- Motor fitted with sleeve bearings (ball bearings optional)

**Max. Recommended Speed**

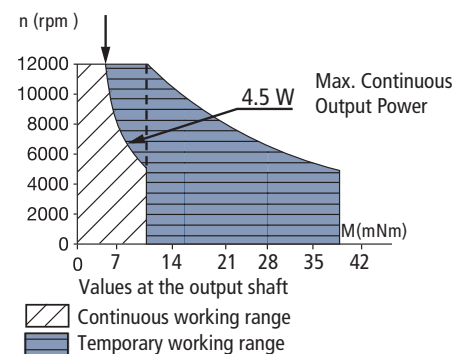

DANAHER MOTION is a trademark of Danaher Corporation. Danaher Motion makes every attempt to ensure accuracy and reliability of the specifications in this publication. Specifications are subject to change without notice. Danaher Motion provides this information "AS IS" and disclaims all warranties, express or implied, including, but not limited to, implied warranties of merchantability and fitness for a particular purpose. It is the responsibility of the product user to determine the suitability of this product for a specific application. ©2004 Danaher Motion.